

MaxGard® Interconnection Systems

Pin and Sleeve Plugs, Receptacles and Systems

1.0 Scope

- 1.1 This document covers multi-contact pin and sleeve, industrial grade, arc-quenching, circuit interrupting-rated electrical plugs, motor plugs, connectors, receptacles, mechanically interlocked receptacles and assorted accessories. Usable in dry, damp, wet, marine and/or hazardous locations for electrical power circuits. Devices are to be rated 30, 60, 100, 200 and/or 400 amperes at 600VAC, 50–400 Hz and 250VDC maximum. Devices are also rated for continuous use in temperatures from -40° C to +130° C. These devices must provide internal environmental seals for marine and extreme wet applications and can be electrically interlocked.
- 1.2 The devices described shall be Thomas & Betts/Russellstoll® MaxGard® catalog numbers as specified.

2.0 Product Classifications (Features)

- 2.1 **Gated Deadfront** — All receptacles and connectors must have a rotating disk on the face of the interior, which provides live contact isolation and environmental separation.
- 2.2 **Delayed Action Arc Containment** — All devices upon disconnect under load shall have provision so the arc is contained and extinguished within the insulation cavity, making it impossible to withdraw a live plug.
- 2.3 **Flap Cover or Screw Cover Option** — Flap cover option must provide weathertight capability by utilizing a spring actuated self-closing flap. Watertight capability shall be obtained by using a gasketed screw cap.
- 2.4 **Polarization** — All devices shall be factory polarized for amperage, voltage, frequency and phase; thus providing a single voltage rating, single interface system.
- 2.5 **Grounding** — The grounding of the device shall be accomplished through a separate center ground (earth) make-first and break-last pole on all devices for complete system grounding.

- 2.6 **Pole Capabilities** — All devices shall accommodate up to four power pins plus a separate center ground pin and they shall be integral with the connector bodies (five pins total).
- 2.7 **Interior Type** — Interiors must be male (pin type) or female (sleeve type). Pins and sleeves shall also be self-aligning and self-wiping/self-cleaning.
- 2.8 **Control Contacts** — All devices must have an option for two control contacts, which shall be make-last and break-first for use in electrical interlocks and/or control circuits. See table **below**.
- 2.9 **Conductor Terminals** — Pin and sleeve connections shall employ solderless pressure-type screw terminals and be sized to accept stranded or solid copper conductors in AWG sizes (max. O.D.s as noted). The screw terminals shall also have socket heads to ensure proper torquing of wires.
- 2.10 **Environmental Seals** — Each device must have an environmental seal or O-ring around all interiors and around each pin and sleeve to prevent water and contaminants from entering the wiring compartment. This provides waterproof capability, even when not mated.
- 2.11 **Hazardous Location** — All standard plugs 30, 60 and 100 amp shall be UL® and CSA listed for hazardous location Class I Division 1, Groups C and D; Class II Division 1, Groups F and G. A hazardous location circuit breaker-protected interlock shall also be applicable to the same environments and possess all the same product features as outlined above. Enclosures shall meet NEMA 8 hazardous outdoor-duty classifications and shall meet shipboard use above deck in accordance with the Department of Transportation (USCG "Green Water").
- 2.12 **Lockout Devices** — Plug connection lockout is achieved by a padlock through plug sleeve housing hole provided for this purpose. On Hazardous Location/Explosion Proof Interlock Receptacles, lockout shall additionally be achieved by separate lockout accessory available from the factory. On standard Interlocks, lockout accessory/construction is available from the factory.

Rating for Pilot/Control Contacts

Contact Rating Code Designation A-600, Table 119.1 — UL 508 Heavy Pilot Duty Load (720 VA/600VAC) Maximum

THERMAL CONTINUOUS CURRENT AMPS	MAXIMUM CURRENT AMPERE									
	120V		240V		480V		600V		MAX. VOLT AMPERE	
	Make	Break	Make	Break	Make	Break	Make	Break	Make	Break
10 (#12 AWG)	60	6	30	3	15	1.5	12	1.2	7200	720

MaxGard® Interconnection Systems

3.0 Materials Requirements

- 3.1 **Housings** — Plug, motor plug, receptacles, connectors and interlock housings, associated covers and caps, screw collars, and clamp holders shall be made of copper-free cast aluminum (max. .004% copper).
- 3.2 **Finish** — All external surfaces except those that provide means of grounding shall be epoxy powder coated to resist corrosion.
- 3.3 **Hardware** — All hardware, external and springs, shall be stainless steel. Cable clamps shall be stainless steel or epoxy powder coated, copper-free cast aluminum.
- 3.4 **Insulators** — All device body insulators shall be molded from glass-reinforced high-strength thermoset polyester, minimum of UL® 94-V0 flammability rated.
- 3.5 **Contacts** — Contacts base material shall be made of a conductive copper alloy (brass CDA485) to prevent dezincification. Accessory material of the contacts shall be made of a compatible corrosion resistant material.
- 3.6 **Environmental Seals** — Environmental gaskets and O-rings shall be made of Neoprene material.

4.0 Design and Construction Requirements

- 4.1 **Circuit Interrupting Rating** — All devices 30, 60, 100 and 200 amperes shall be tested to be interrupted at 150% of rated current. Additionally, all devices shall be designed and tested to interrupt 100% of rated current.
- 4.2 **Wiring** — All devices shall be wired from the rear requiring no disassembly of the pins and/or sleeves from the insulated body.
- 5.0 **Applicable Documents (Compliances)**
 - 5.1 **Underwriters Laboratories (UL)** — The devices specified herein shall be listed in applicable sections of UL Standards 1010, 231, 1682 and 1686, File Nos. E2630, E57324, E68085, E123752.
 - 5.2 **Canadian Standard Association (CSA)** — The devices specified shall be listed in the applicable sections of CSA C22.2-182.1, File Number LR14096.
 - 5.3 **International Electro-Technical Commission (IEC)** — The 30-, 60- and 100-ampere devices specified shall have been tested and comply with IEC 309-1.
 - 5.4 **Federal Department of Transportation** — Refrigerated National Shipboard location devices shall meet and comply with Federal Register volume 47, number 68, subpart 111.79.
 - 5.5 **Standards** — The devices specified shall comply with Military Standards MIL-STD-105 and 1344; ASTM Standards D570 and D2565; NEMA Standard PR4-1983; and OSHA regulations when installed in accordance with the National Electrical Code® (NEC®).

5.6 NEMA 250 Enclosures Standard

- NEMA 1** — General Purpose for indoor use; guards against contact with equipment.
- NEMA 3R** — Outdoor use primarily to protect against rain, sleet, wind-blown dust and damage from external ice formation.
- NEMA 4** — Indoor or outdoor use to protect against windblown dust and rain; splashing and hose-directed water.
- NEMA 4X** — Watertight, dust-tight corrosion-resistant for indoor or outdoor applications.
- NEMA 6** — Watertight, casual/temporary immersion.
- NEMA 7** — Class I (Hazardous) for indoor use in Class I areas, per NEC®.
- NEMA 8** — Class I (Hazardous) for indoor use in Class I, oil-immersed equipment.
- NEMA 9** — Class II (Hazardous) for indoor use in Class II areas, per NEC®.
- NEMA 12** — Industrial use, dust-tight for indoor use to protect against dust, falling dirt and dripping non-corrosive liquids.

NEC and National Electrical Code are registered trademarks of the National Fire Protection Association, Inc.

MaxGard® Interconnection Systems

Single Polarization/Multiple Service* Assigned Voltages and Wiring Systems

Russellstoll® Pin and Sleeve Power Connectors

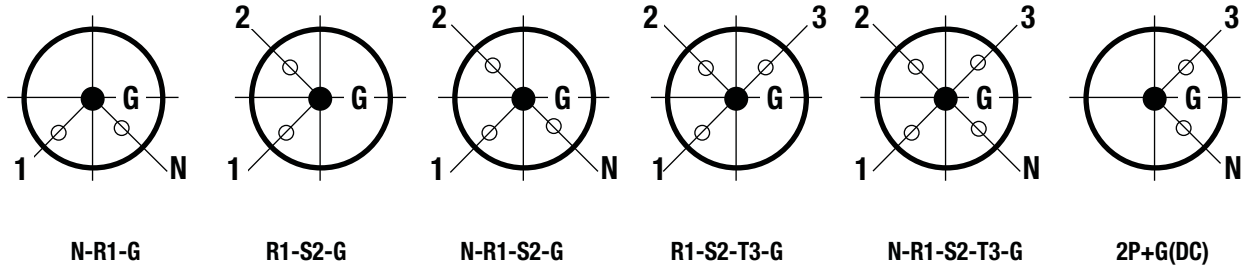

VOLTAGE ASSIGN. NO.	VOLTAGE	VOLTAGE ASSIGN. NO.	VOLTAGE	VOLTAGE ASSIGN. NO.	VOLTAGE	VOLTAGE ASSIGN. NO.	VOLTAGE	VOLTAGE ASSIGN. NO.	VOLTAGE	VOLTAGE ASSIGN. NO.	VOLTAGE	INDEX
101	220V-50 Hz	201	380V-50 Hz	301	220/380V-50 Hz	401	380V-50 Hz	501	220/380V-50 Hz			01
103	127V-50 Hz	203	220V-50 Hz	303	220/127V-50 Hz	403	220V-50 Hz	503	220/127V-50 Hz			03
104	277V-60 Hz	204	480V-60 Hz	304	277/480V-60 Hz	404	3Ø 480V-60 Hz	504	3ØY 277/480V-60 Hz			04
105	250V-50 Hz	205	440V-50 Hz	305	250/440V-50 Hz	405	3Ø 440V-50 Hz	505	3Ø 250/440V-50 Hz			05
107	125V-60 Hz	207	250V-60 Hz	307	125/250V-60 Hz	407	3Ø 250V-60 Hz	507	3ØY 125/250V-60 Hz			07
108	220V-60 Hz	208	380V-60 Hz	308	220/380V-60 Hz	408	3Ø 380V-60 Hz	508	3Ø 220/380V-60 Hz			08
109	100V-60 Hz	209	220V-60 Hz	309	100/220V-60 Hz	409	3Ø 220V-60 Hz	509	3Ø 100/220V-60 Hz			09
111	115V-400 Hz	211	220V-400 Hz	311	220/115V-400 Hz	411	220V-400 Hz	511	220/115V-400 Hz			11
—	—	—	—	—	—	—	—	513	230V DC	613	250 VDC	13
114	347V-60 Hz	214	600V-60 Hz	314	347/600V-60 Hz	414	3Ø 600V-60 Hz	514	3ØY 347/600V-60 Hz			14
115	100V-50 Hz	215	220V-50 Hz	315	100/220V-50 Hz	415	3Ø 220V-50 Hz	515	3Ø 100/220V-50 Hz			15
116	120V-60 Hz	216	208V-60 Hz	316	120/208V-60 Hz	416	3Ø 208V-60 Hz	516	3ØY 120/208V-60 Hz			16
117	120V-400 Hz	217	208V-400 Hz	317	120/208V-400 Hz	417	3Ø 208V-400 Hz	517	3Ø 120/208V-400 Hz			17
—	—	—	—	—	—	208V	—	—	—	618	28 VDC	18
—	—	—	—	—	—	—	—	—	—	—	—	20
—	—	221	440V-60 Hz	321	250/440V-60 Hz	421	3Ø 440V-60 Hz	521	3ØY 250/440V-60 Hz			21
—	—	—	—	—	—	250V	—	Reserved	—	—	—	22
—	—	—	—	—	—	480V	—	Reserved	—	—	—	23
—	—	—	—	—	—	600V	—	Reserved	—	—	—	24

MaxGard® receptacles and plugs may be furnished in any of the above voltage and phasing systems.

To order any device in a voltage and phasing not shown in the preceding catalog pages, substitute the Voltage Assignment Number in the **above** chart for that portion of the listed catalog number appearing in **boldface** type.

Example: 200 Amp Weathertight Receptacle with Flap Cover, Angle Adapter and Junction Box for 3Ø 480 volt (3-pole and ground) is DF2404FRAB0.

To change to 3Ø 208 volt, the catalog number becomes DF2416FRAB0.

Note: All devices may be furnished with two control contacts. Add "K" to the end of the catalog number, in place of last position Ø.

*** Dual-Voltage or Multiple-Service Applications** (for any given polarization number) — Example: A factory installation may consist of all receptacles specified and wired at polarization "507." This is a 3ph. Y-125/250V-60 Hz supply. However, all circuit requirements "below" (507) can also be met; for instance a "207" plug will draw phasing for 250V-60 Hz operation of equipment as well, while another ".507" receptacle supplies power for a 3-phase motor installation. See chart **above**.

For non-interrupting polarizations at 45, 90, 150, 300, 600A ratings, consult Technical Services.

MaxGard® Interconnection Systems

Male Plug

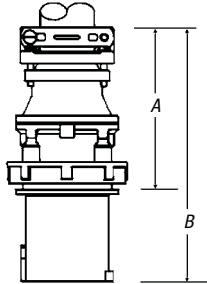

AMP	A	B
30	4 ³ / ₄ "	7 ⁷ / ₈ "
60	5 ¹ / ₂ "	9 ¹ / ₈ "
100	6 ¹ / ₂ "	10 ¹ / ₈ "
200	9"	13 ³ / ₄ "
400	12 ⁵ / ₈ "	17 ⁵ / ₈ "

Connector

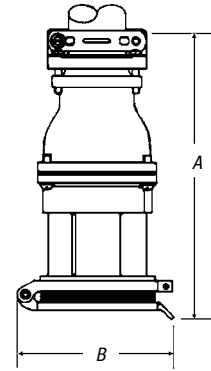

AMP	A	B
30	8 ³ / ₄ "	5 ¹ / ₈ "
60	10"	5 ³ / ₈ "
100	11 ¹ / ₈ "	5 ³ / ₈ "
200	15"	9 ¹ / ₂ "
400	19 ⁵ / ₈ "	10 ³ / ₄ "

Russellstoll® Pin and Sleeve Power Connectors

Male Inlet

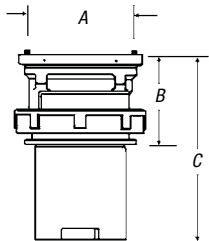

AMP	A	B	C
30	2 ⁵ / ₈ "	2 ¹ / ₂ "	5 ¹ / ₂ "
60	3 ³ / ₈ "	2 ¹ / ₂ "	5 ¹ / ₂ "
100	3 ³ / ₈ "	2 ¹ / ₂ "	5 ¹ / ₂ "
200	5 ¹ / ₄ "	3 ¹ / ₂ "	9 ¹ / ₄ "
400	3 ⁵ / ₈ "	4 ³ / ₈ "	9 ¹ / ₄ "

Receptacle with Angle Enclosure

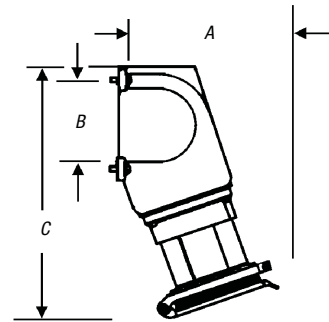

AMP	A	B	C
30	6 ⁵ / ₈ "	3 ¹ / ₈ "	9 ¹ / ₈ "
60	7 ¹ / ₈ "	4"	11 ¹ / ₈ "
100	7 ¹ / ₂ "	4"	11 ¹ / ₈ "
200	—	—	—
400	—	—	—

(Flap covers shown — screw covers available. On all, screw covers have nominal effect on outside dimensions.)

MaxGard® Interconnection Systems

Receptacle with Angle Adapter and DJB Junction Box

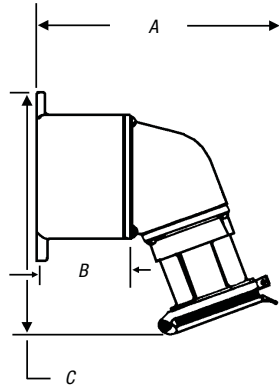

AMP	A	B	C
30	9 ¹ / ₈ "	3"	9 ⁵ / ₈ "
60	10 ¹ / ₂ "	3"	9 ³ / ₄ "
100	10 ³ / ₄ "	3 ³ / ₄ "	10"
200	15 ³ / ₄ "	6 ⁵ / ₈ "	14 ⁵ / ₈ "
400	25 ¹ / ₄ "	12"	20 ³ / ₄ "

Receptacle with Angle Adapter

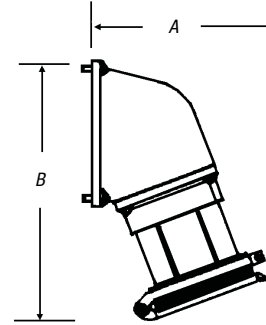

AMP	A	B
30	6 ¹ / ₈ "	9 ⁵ / ₈ "
60	7 ¹ / ₂ "	9 ³ / ₄ "
100	7"	10"
200	9 ¹ / ₂ "	14 ⁵ / ₈ "
400	13 ¹ / ₄ "	20 ³ / ₄ "

(Flap covers shown — screw covers available. On all, screw covers have nominal effect on outside dimensions.)

Receptacle Only

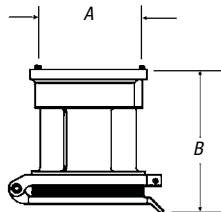

AMP	A	B
30	2 ⁷ / ₈ "	4 ¹ / ₂ "
60	3 ³ / ₈ "	5 ¹ / ₈ "
100	3 ⁵ / ₈ "	5 ³ / ₈ "
200	5 ¹ / ₄ "	6 ⁵ / ₈ "
400	7"	7 ¹ / ₈ "